

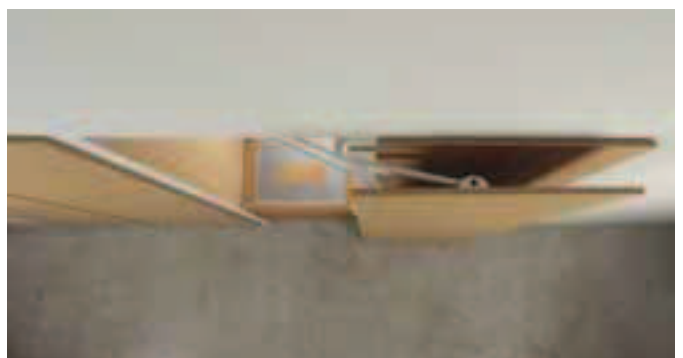

ΜΗΧΑΝΙΣΜΟΙ ΝΤΟΥΛΑΠΑΣ

ΜΟΤΙΟΝ-V | ΜΗΧΑΝΙΣΜΟΣ ΝΤΟΥΛΑΠΑΣ

Πρωτοποριακός μηχανισμός από τη **SERVETTO** με αθόρυβη λειτουργία & τέλεια αισθητική.

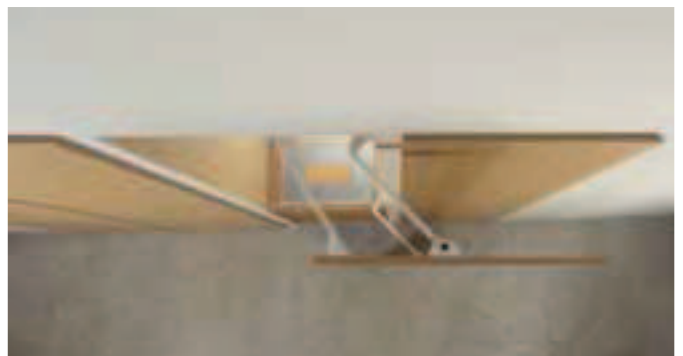

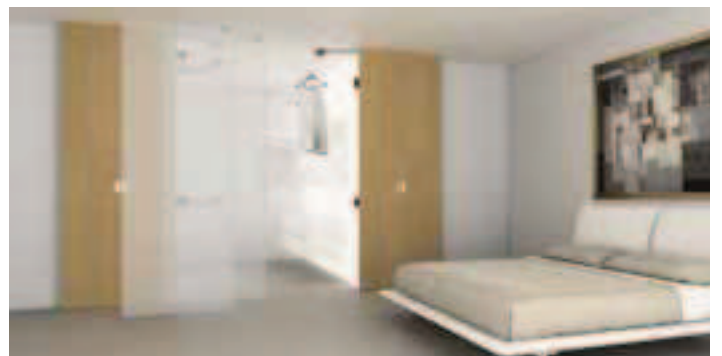



ΜΗΧΑΝΙΣΜΟΣ ΜΟΤΙΟΝ-V V0 ΑΝΟΙΓΟΜΕΝΗΣ ΠΟΡΤΑΣ ΜΕ ΣΩΛΗΝΑ



	χρώμα	κωδικός προμηθευτή	κωδικός παραγγελίας	συσκευασία	διαθ/τητα
εσωτερικό 480 - 580 mm	γκρι	MTNV0AA00	121301.0012	σετ 1	

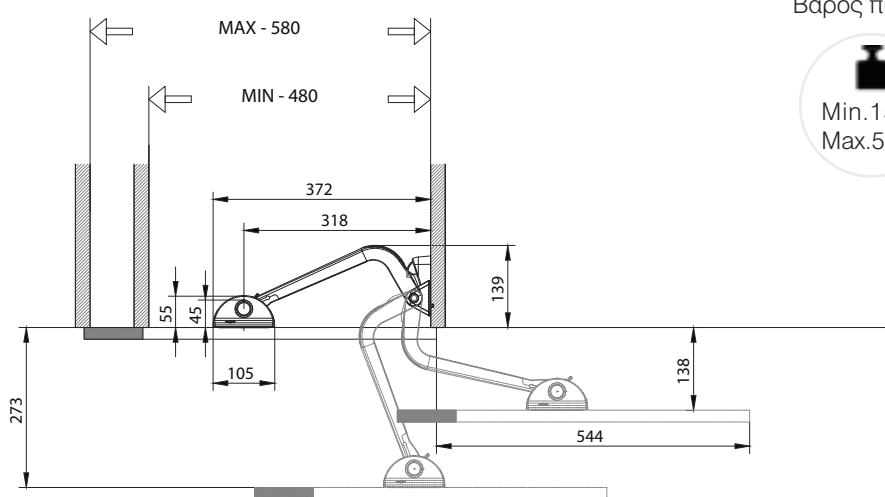

Βάρος πόρτας



ΜΗΧΑΝΙΣΜΟΣ ΜΟΤΙΟΝ-V V1 ΑΝΟΙΓΟΜΕΝΗΣ ΠΟΡΤΑΣ ΜΕ ΣΩΛΗΝΑ

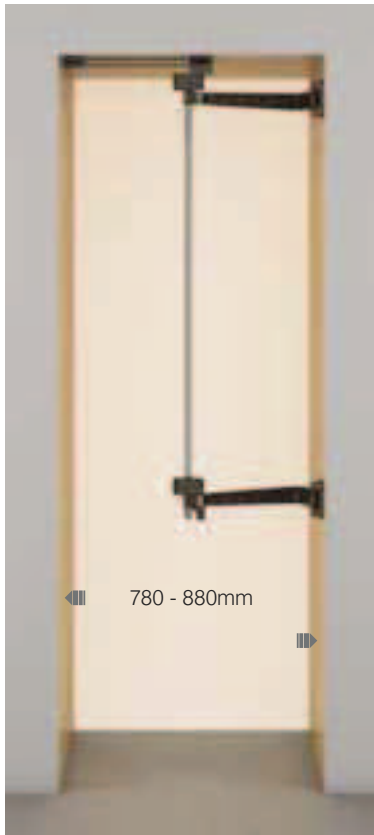

χρώμα	κωδικός προμηθευτή	κωδικός παραγγελίας	συσκευασία	διαθ/τητα
εσωτερικό 780 - 880 mm	γκρι	MTNV1AA00	121301.0001	σετ 1

Βάρος πόρτας

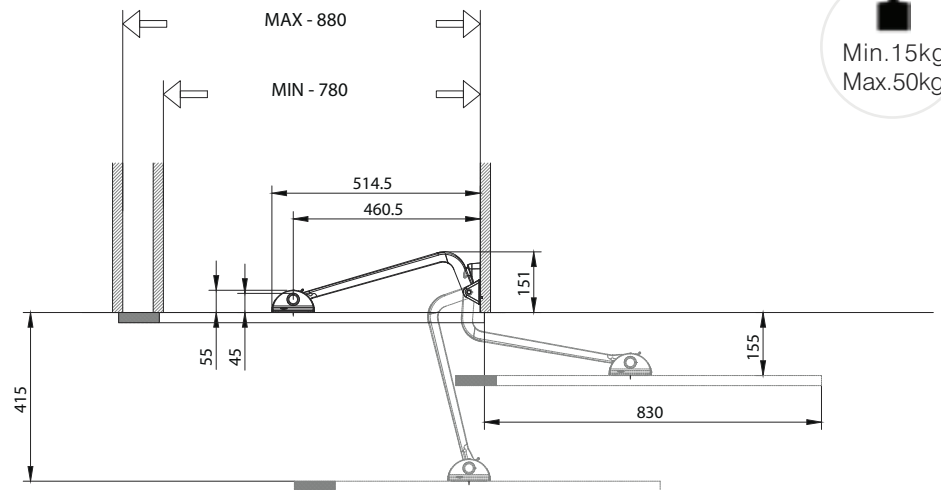

ΜΗΧΑΝΙΣΜΟΣ ΜΟΤΙΟΝ-V V2 ΑΝΟΙΓΟΜΕΝΗΣ ΠΟΡΤΑΣ ΜΕ ΣΩΛΗΝΑ



χρώμα	κωδικός προμηθευτή	κωδικός παραγγελίας	συσκευασία	διαθ/τητα
εσωτερικό 880 - 980 mm	γκρι	MTNV2AA00	121301.0000	σετ 1

Βάρος πόρτας

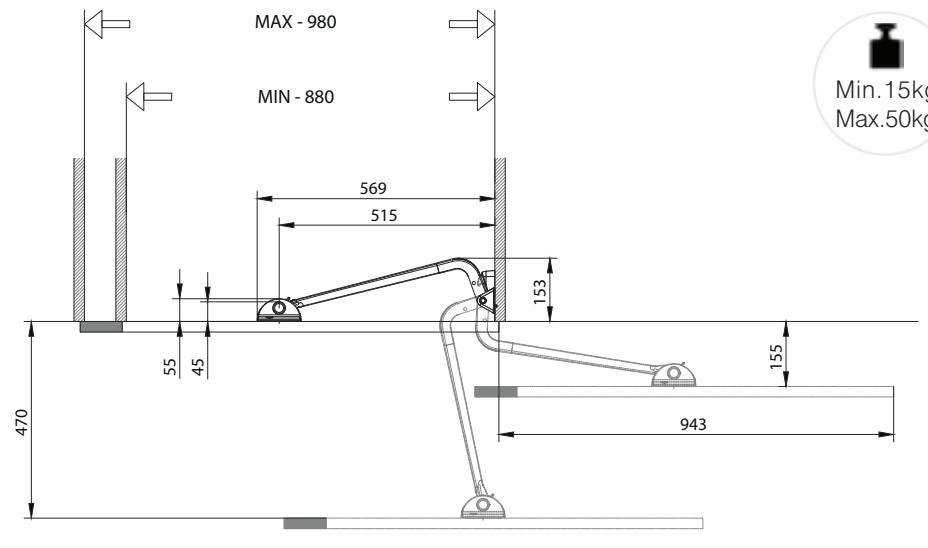

ΚΑΘΕ ΜΗΧΑΝΙΣΜΟΣ **ΜΟΤΙΟΝ-V** ΠΕΡΙΛΑΜΒΑΝΕΙ:



ΟΔΗΓΙΕΣ ΤΟΠΟΘΕΤΗΣΗΣ

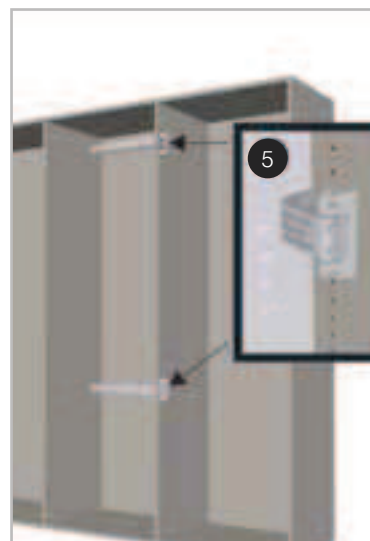
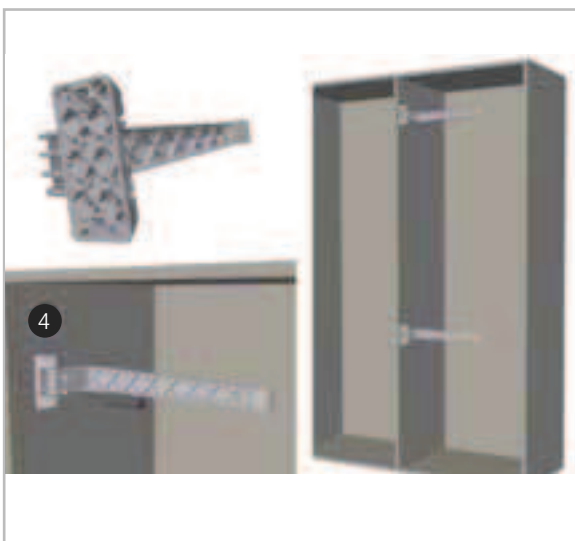
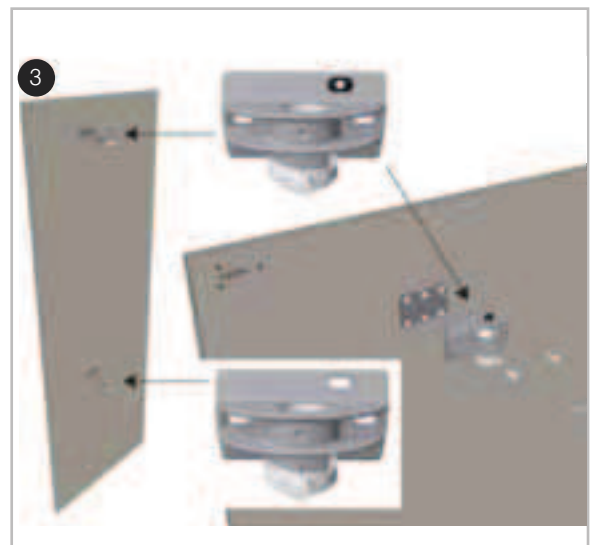

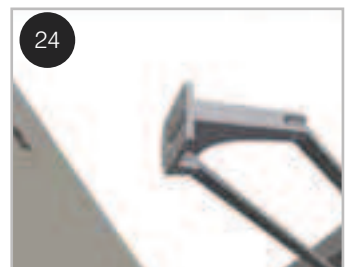
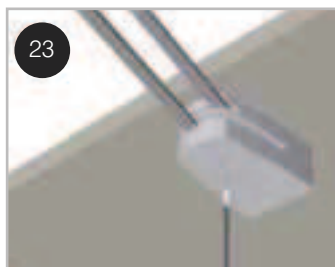
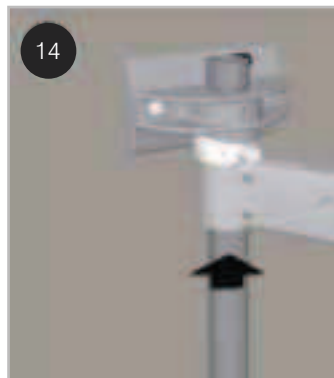
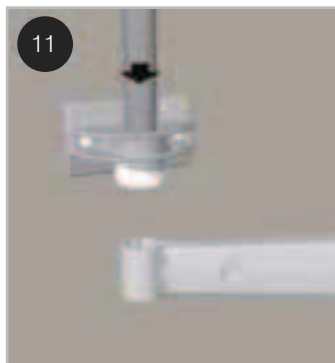
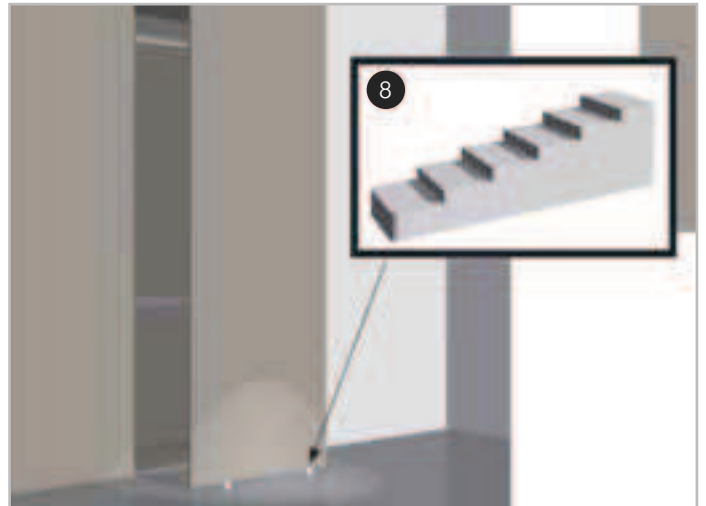

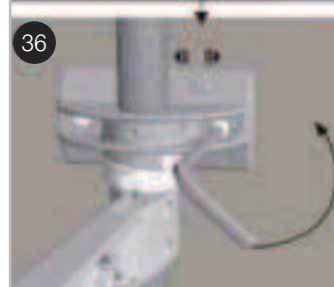

ΑΥΤΟΜΑΤΙΣΜΟΣ ΓΙΑ ΜΟΤΙΟΝ-V



χρώμα	κωδικός προμηθευτή	κωδικός παραγγελίας	συσκευασία	διαθ/τητα
γκρι	AUTMTNKTG	121301.0008	σετ 1	



Βάρος πόρτας

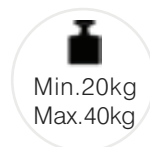

ΚΟΝΤΡΟΛ ΧΕΙΡΙΣΜΟΥ ΕΩΣ 10 ΜΟΤΙΟΝ-V

χρώμα	κωδικός προμηθευτή	κωδικός παραγγελίας	συσκευασία	διαθ/τητα
μαύρο	SWCO02500	121301.0011	1 τεμ.	

ΚΑΘΕ ΑΥΤΟΜΑΤΙΣΜΟΣ ΜΟΤΙΟΝ-V ΠΕΡΙΛΑΜΒΑΝΕΙ:

Οδηγό, στηρίγματα, μετασχηματιστή 100-240V στα 12V, καλώδιο παροχής 1,5m, συνδετικό καλώδιο μεταξύ μοτέρ και μετασχηματιστή 1,5m, κοντρόλ με 1 κουμπί προγραμματισμένο (η μπαταρία συμπεριλαμβάνεται).

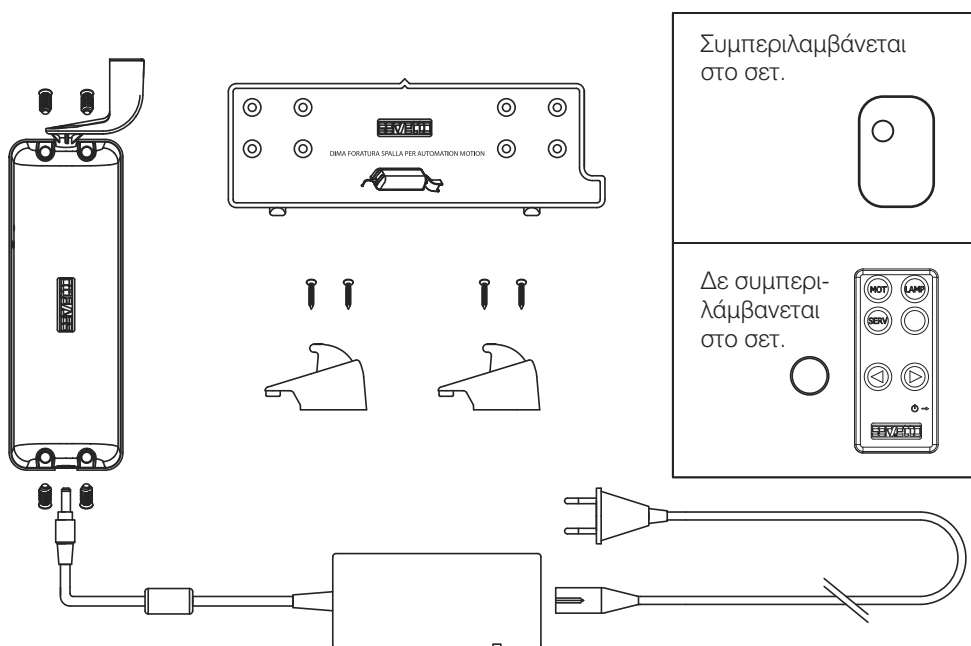

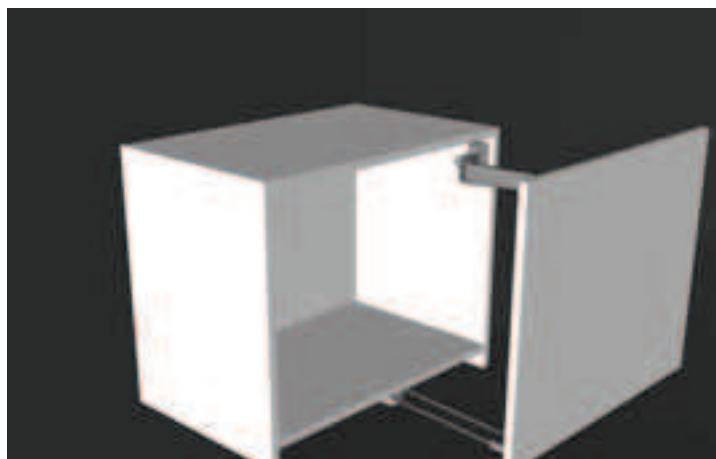

ΜΗΧΑΝΙΣΜΟΣ MOTION-VS0 ΑΝΟΙΓΟΜΕΝΗΣ ΠΟΡΤΑΣ ΜΕ ΣΩΛΗΝΑ

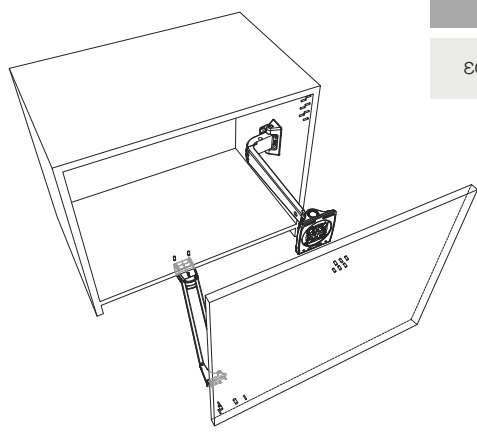

	χρώμα	κωδικός προμηθευτή	κωδικός παραγγελίας	συσκευασία	διαθ/τητα
εσωτερικό 520 - 600 mm	γκρι	MTNVS0A00	-	σετ 1	

Βάρος πόρτας

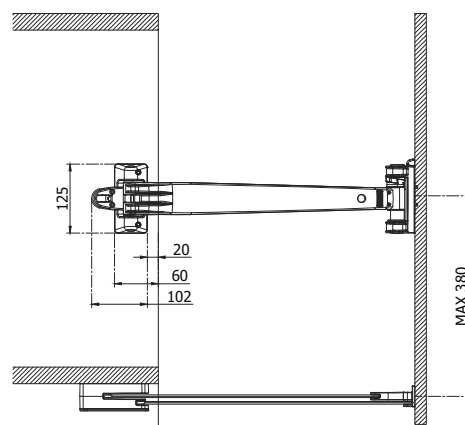
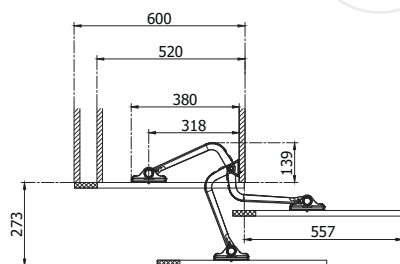

Σημείωση: Όλοι οι μηχανισμοί MOTION-VS διατίθενται κατόπιν παραγγελίας στα παρακάτω χρώματα: λευκό, καφέ, χρυσό & χρώμιο γυαλιστερό. Για περισσότερες πληροφορίες επικοινωνήστε με το τμήμα εξυπηρέτησης πελατών.

ΜΗΧΑΝΙΣΜΟΣ MOTION-VS1 ΑΝΟΙΓΟΜΕΝΗΣ ΠΟΡΤΑΣ ΜΕ ΣΩΛΗΝΑ

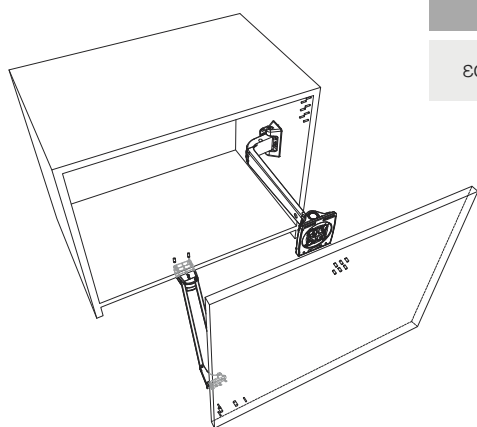

ⓘ	χρώμα	κωδικός προμηθευτή	κωδικός παραγγελίας	συσκευασία	διαθ/τητα
εσωτερικό 820 - 900 mm	γκρι	MTNVS1A00	121301.0009	σετ 1	☎

Βάρος πόρτας

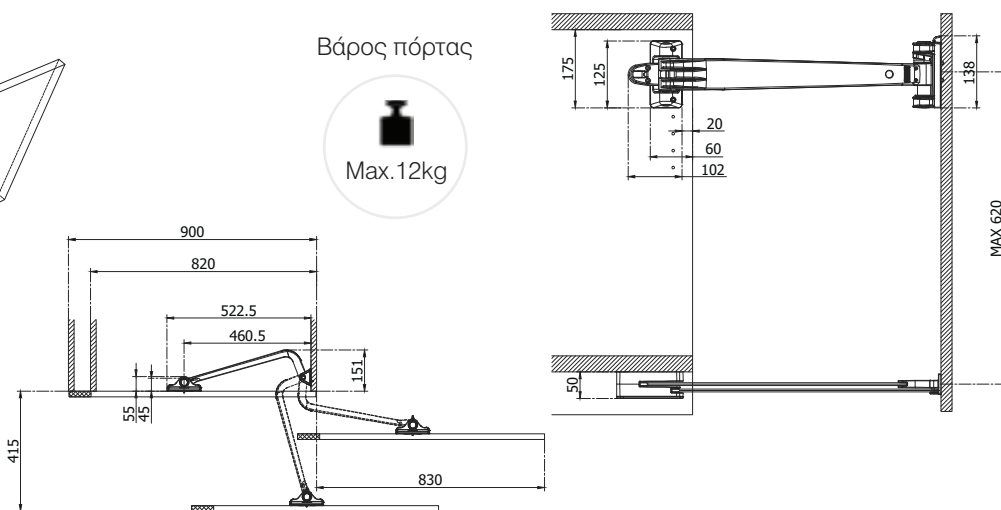

ΚΑΘΕ ΑΥΤΟΜΑΤΙΣΜΟΣ MOTION-VS ΠΕΡΙΛΑΜΒΑΝΕΙ:

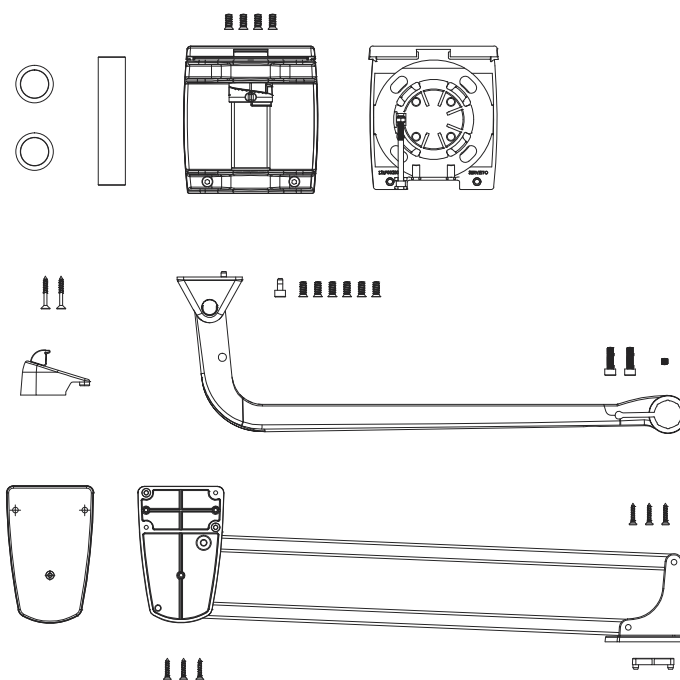

Για τις οδηγίες διάτρησης του μηχανισμού ντουλάπας Motion-VS επικοινωνήστε με το τμήμα εξυπηρέτησης πελατών.

Σημείωση: Όλοι οι μηχανισμοί MOTION-VS διατίθενται κατόπιν παραγγελίας στα παρακάτω χρώματα: λευκό, καφέ, χρυσό & χρώμιο γυαλιστερό. Για περισσότερες πληροφορίες επικοινωνήστε με το τμήμα εξυπηρέτησης πελατών.

 210 28 88 700